

E-Z POUR 100 MELTER

WITH PUMP/APPLICATOR

This manual is furnished with each new CRAFTCO E-Z POUR 100 MELTER. The manual will help your machine operators learn to run the sealer properly and understand its mechanical functions for trouble-free operation.

Your CRAFTCO E-Z POUR 100 MELTER is designed to give excellent service and save maintenance expense. However, as with all specially engineered equipment, you can get best results at minimum costs if:

- (1) You operate your machine as instructed in this manual, and
- (2) Maintain your machine regularly as stated in this manual.

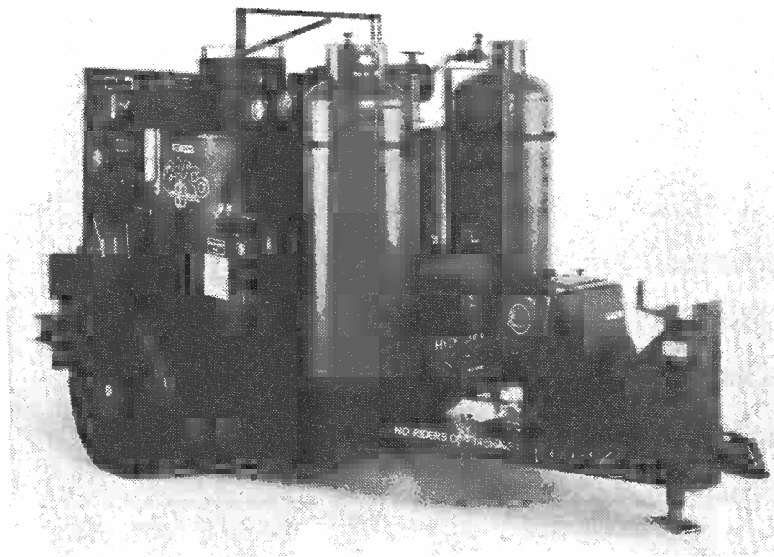

TABLE OF CONTENTS

Safety Precautions.	3
Warranty.	4
Warranty Claim Instructions.	5
Specifications.	6
Operating Instructions.	7
Machine Start Up.	8
Temperature Control Calibration.	12
Burner Control Wiring Diagram.	13
Loading Machine.	13
Shutdown & Cleaning.	13
Storing Machine.	14
Burner Trouble Shooting Guide.	14
Trouble Shooting Chart.	15
Service Instructions.	16
Maintenance Instructions.	16
Maintenance Chart.	17
Pump Section.	18
Fluids & Lubricants.	19
General Maintenance Items.	20
Instructions for Ordering Parts.	20
Numerical Parts List.	21-23
Hydraulic Piping Sequence.	24-25
LPG Piping Sequence.	25-26
E-Z Pour 100 Melter (Propane) Diagram.	27
Control Box / Optional Gravity Feed.	28
Hydraulic Piping Diagram.	29
L.P.G. Piping Diagram.	30

SAFETY PRECAUTIONS

*High operating temperatures of Sealant & Machine require protective clothing and gloves be worn by operator.

*Always wear eye protection.

*Observe all **CAUTION & WARNING** signs posted on machine.

*Avoid the entrance of water into any part of the machine. Water will displace heat transfer oil or sealant which could be hazardous to personnel surrounding the machine when it reaches operating temperatures.

*Avoid bodily contact with hot sealant material or heat transfer oil, serious burns may result.

*Read Operator Manual thoroughly before operating machine.

*Make sure operator is familiar with machine operation.

*Do not operate in closed building or confined areas.

*Shut-down burner & engine prior to refilling LPG Tanks.

*When adding solid material to Sealant tank, stop mixer, lift lid, place material onto lid and close lid before restarting mixer. Hot material could splash and cause serious burns if this procedure is not followed.

*Keep hands, feet and clothing away from all moving parts.

*Always keep a fire extinguisher near the unit. Maintain extinguisher properly and be familiar with its use.

*Do not exceed 525° F. for heat transfer oil temperature.

*Do not overfill heat transfer oil level. Expansion of oil during heat up could cause overflow. Check oil each day before starting burner, add oil to top mark on dipstick if required (at 70° F.). Use only recommended heat transfer oil and change after 500 hours of operation or one year, whichever occurs first.

*Follow operating instructions for starting and shut-down of burner. Instructions are mounted on control box.

*Calibrate temperature control prior to initial operation and each 50 hours of operation.

*Replace any hoses which show signs of wear, fraying or splitting. Be sure all fittings and joints are tight and leakproof.

*Precaution is the best insurance against accidents.

*The E-Z Pour 100 Melter should not be left unattended with burner lit.

*Tighten all bolts and screws after every 100 hours of operation.

CRAFCO, INC. assumes no Liability for an accident or injury incurred through improper use of the machine.

E-Z POUR 100 MELTER LIMITED WARRANTY

Crafco, Inc., through its authorized distributor, will replace for the original purchaser free of charge any parts found upon examination by the factory at Chandler, Arizona, to be defective in material or workmanship. This warranty is for a period within 60 days of purchase date, but excludes engine/or components, tires, and battery as these items are subject to warranties issued by their manufacturers.

After 60 days, Crafco, Inc. warrants structural parts, excluding heating system, hydraulic components, and electrical components for a period of (1) one year from date of delivery. Crafco, Inc., shall not be liable for parts that have been damaged by accident, alteration, abuse, improper lubrication/maintenance, normal wear, or other cause beyond our control.

The warranty provided herein extends only to the repair and/or replacement of those components on the equipment covered above and does not cover **labor** costs. The warranty does not extend to incidental or consequential damages incurred as a result of any defect covered by this warranty.

All transportation and labor costs incurred by the purchaser in submitting or repairing covered components must be bore by the purchaser.

Crafco, Inc., specifically disavows any other representation, warranty or liability related to the condition or use of the product.

Warning - Use of replacement parts other than genuine Crafco parts may impair the safety or reliability of your equipment and nulifies any warranty.

CRAFCO, INC.

WARRANTY CLAIM INSTRUCTIONS

Please follow the instructions stated below when calling in a Warranty Claim. Failure to follow these procedures may be cause to void the warranty.

- (1) Call your local CrafcO Distributor. If you do not know who your local distributor is, call a CrafcO Customer Service Representative, (Toll Free 1-800-528-8242) for name, location and telephone number.
- (2) On contacting the Distributor, be prepared to identify the machine type, model number and serial number, also the date of purchase if available.
- (3) Should the cause of the malfunction be a defective part, the Distributor will advise you of the procedure to follow for a replacement.
- (4) The warranty is valid only for parts which have been supplied or recommended by CrafcO, Inc.

If you have any additional questions regarding warranty repairs and parts, please do not hesitate to call toll free 1-800-528-8242.

CRAFCO, INC.
6975 WEST CRAFCO WAY
CHANDLER, AZ 85226
(602) 276-0406
Toll Free 1-800-528-8242

SPECIFICATIONS

Vat Capacity	100 Gallons
Melt Capacity	80 Gallons/Hour
Heat Transfer Oil Required	27 Gallons at 70° F.
Tank Construction	Double Boiler Type
Tank Opening Size	14" x 18"
Maximum Heat Input	Vapor Burner 205,000 BTU's
Burner & Temperature Control	Automatic - Fail Safe
Engine - Onan ELITE 12.5 - Propane Fueled	Single Cylinder 12½ HP @ 3600 rpm
Drive Mechanism	All Hydraulic with infinite speed forward & reverse action.
Mixer	Full sweep mixer with 2 horizontal paddles.
Axle	Single - 3,500 lbs. Capacity.
Tires (2)	185R-14-8 ply rating. (1850 lbs. capacity each.
Dry Weight	Approximately 2,600 lbs.
Propane Bottles (2)	100 lbs. each.

E-Z POUR 100 MELTER OPERATING INSTRUCTIONS

INTRODUCTION

The CRAFCO E-Z Pour 100 Melter was developed to melt CRAFCO Brand Sealants. However, it will work equally well with all road asphalts and federal specification crack or joint sealants.

DO NOT operate machine without following these instructions:

1. Fill propane tanks.
2. Check engine crankcase oil (refer to Engine Operator's Manual).
3. Check hydraulic fluid level, at ambient temperature. Add fluid if necessary to bring fluid to correct level.
4. Check heat transfer oil supply. Check level at ambient temperature, machine level. At 70° F., oil should be at the top mark. DO NOT overfill, or spillage may occur when machine reaches operating temperature.
5. All valves should be in closed position and temperature control box set at "OFF".
6. Applicator hose can be kept warm and ready for use by storing in heating chamber before using machine. Close heating doors after hose and wand have been coiled in chamber.
7. Check temperature control calibration.

OPERATION OF CRAFTCO E-Z POUR 100 PROPANE MELTER MACHINE START UP

TO START

1. Fully open the Damper Vent Fig. A(1), Page 9.
2. Set Temperature Dial to "OFF".
3. Open valves on propane bottles, line valves Fig. A(2) (3) page 9. Depress Choke-Primer Button approximately 2 seconds D(13) page 11.
4. Start Engine.
5. Turn Temperature Dial to desired temperature setting.

CAUTION:

If burner does not ignite the first time, turn temperature dial to off. Turn temperature dial to desired setting. Burner should ignite. If burner still does not ignite, determine cause of malfunction (see Trouble Shooting Guide).

6. Allow the heating oil to continue to heat. When sealant material reaches a liquid state, engage the agitator by moving the agitator lever either forward or backward. If agitator does not move, allow material to heat longer. Jamming of agitator shaft causes hydraulic oil to overheat and machine damage could occur.
7. When sealant reaches correct application temperature Fig. A(11) page 9, open main tank valve, open recirculation valve Fig. C(8) and close applicator valve Fig. C(9). Put sealant pump in reverse (Suction) mode. When pump turns freely, reverse sealant pump flow (Discharge) Fig. C(10). This circulates sealant back into tank.
8. Check the sealant temperature at material pump. This indicates the temperature of sealant flowing through lines.
9. When application of sealant is desired, remove the hose from the rear of machine. Attach hose to hand applicator. Be sure to hand tighten only. Place applicator in rear tank opening Fig. F(15), with the hand wand valve in the ON position Fig. F(16).
10. Open applicator valve Fig. C(9).
11. Close the recirculation valve Fig. C(8). **IMPORTANT:** Adjust the valve to get the desired amount of flow from the applicator wand given your applicator needs. You do not need to close the valve all the way for application. If material does not flow from wand, the hose may need to be warmed. Heat hose by placing in heating chamber to liquify sealant in hose, then repeat procedure.
12. Extreme care should be taken when changing or installing applicator tips. If the material is hot the material pump must be put in the "Suction" mode. This will insure against hot material pumped from wand. Sealant material is hot and can cause skin burns.
13. To apply sealant to joint, remove hand applicator from rear tank opening. Make sure the hand wand valve is closed. When applicator wand is over joint, open hand valve and apply sealant.
14. To prevent hose from cooling, place the applicator wand in the rear tank opening when not to be used for 2 minutes or more. Always close hand wand prior to inserting wand in tank opening. Open hand valve to recirculate back into tank and keep hose warm.

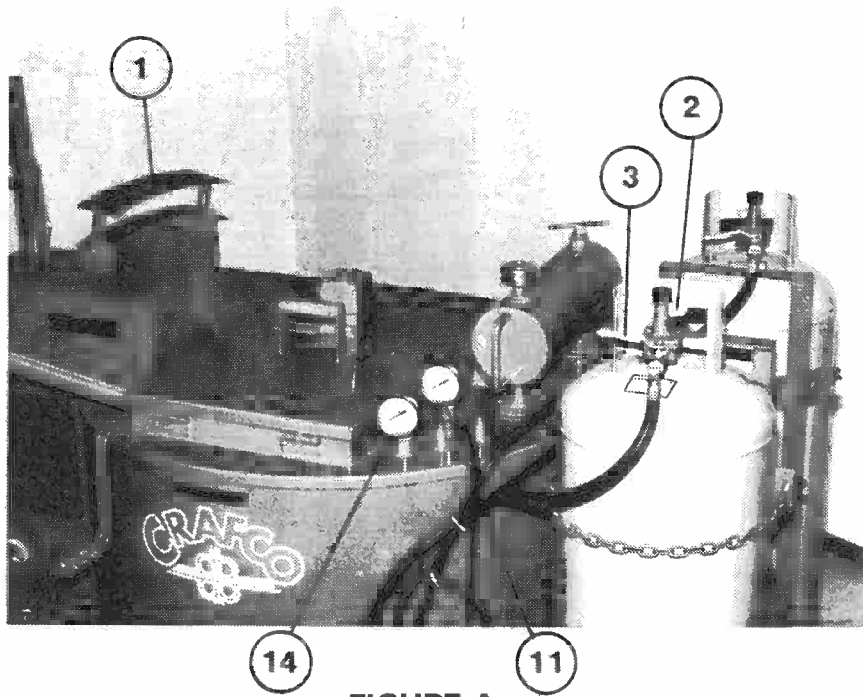

FIGURE A
START UP

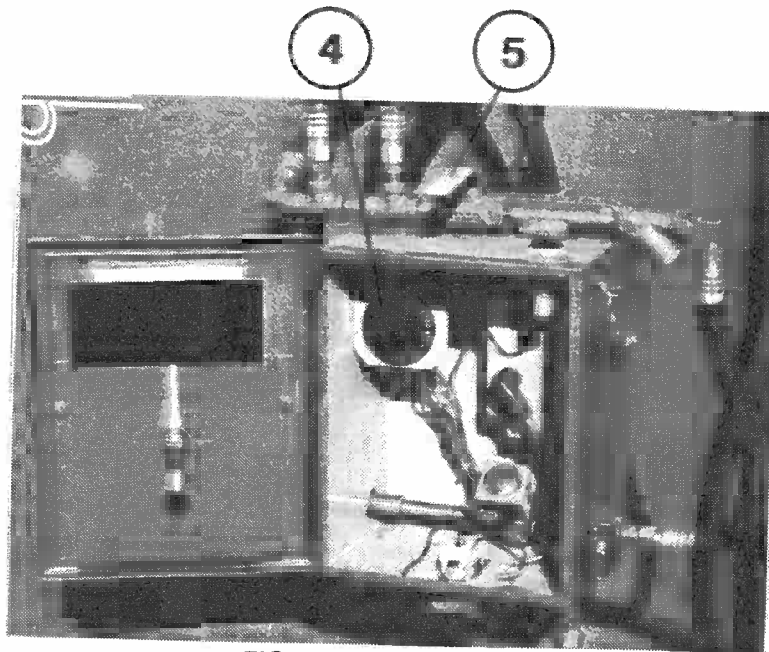

FIGURE B Start Up

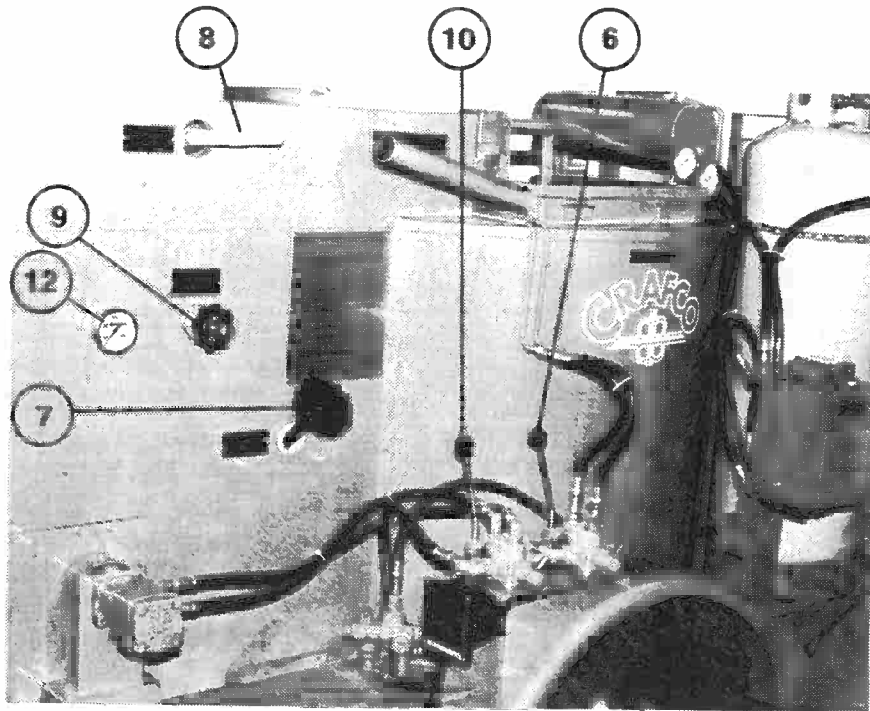

FIGURE C Start Up

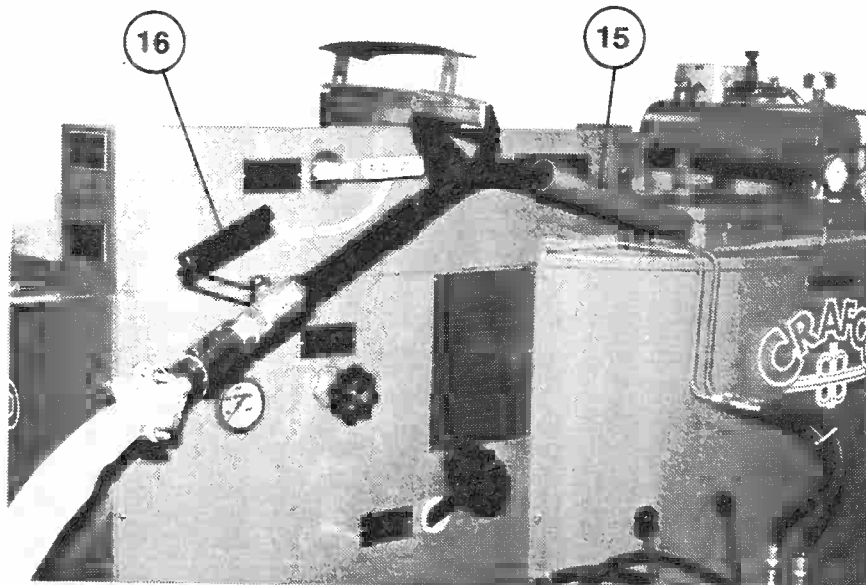

FIGURE F

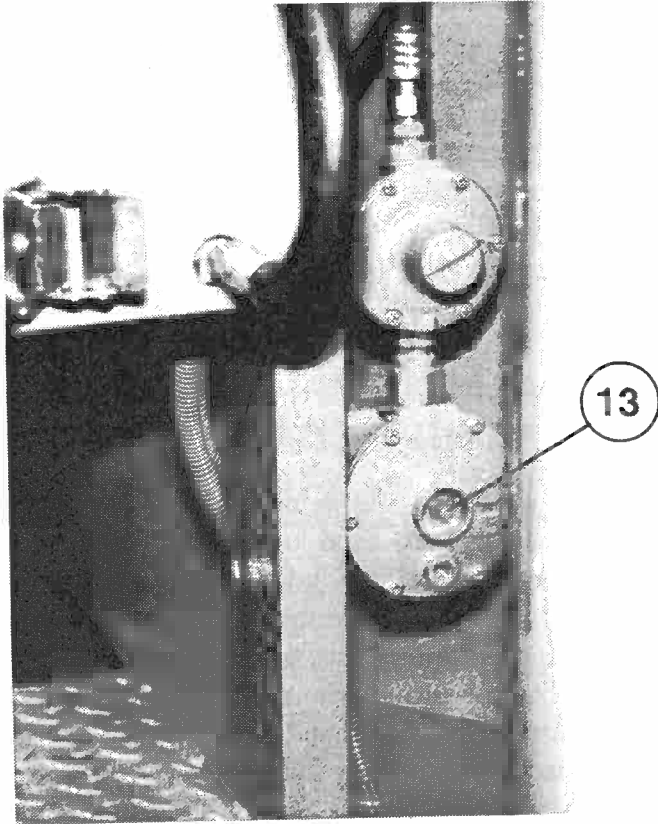

FIGURE D Start Up

CHECKING TEMPERATURE CONTROL CALIBRATION

The temperature control system is calibrated at the factory during testing; however, it is good practice to check the calibration when the machine is first put into operation. And also checked again periodically. (Each 50 hours of operation is recommended.) The gauge (Fig. A(14), Page 9), registers the actual temperature of the heat transfer oil and it should coincide with the temperature control hand knob setting (Fig. B(4), Page 9).

To check the calibration, first the machine must be level and the following procedure must be followed - check heat transfer oil level (at 70° F.) must be high enough to submerge the temperature gauge probe. Start up the burner. Set temperature control hand knob at about 250° F. Leave burner on until 200° F. registers on the temperature gauge. Slowly turn the temperature control hand knob down until a click is heard and/or the burner shuts off. If the temperature control hand knob, at this point, reads differently than the temperature gauge, recalibration is required.

RECALIBRATING THE TEMPERATURE CONTROLS

To recalibrate the temperature control, set the temperature control knob to 200° F. When the burner shuts off, carefully pull the hand knob off the spindle. Be careful not to move the spindle during this operation. With a jeweler's screwdriver (or the flattened end of a paper clip) turn the adjusting screw inside the spindle *counterclockwise* no more than 1/8 turn to start the burner, to increase the temperature (1/8 turn will raise the temperature 15° F. to 20° F.), continue turning the screw each time the burner cuts out until the gauge reads 200° F. Carefully replace hand knob. Both the hand knob and the temperature gauge should now read approximately 200° F.

CAUTION:

Extreme care must be used when operating this equipment. Safety is the result of being careful and paying attention to details. Remember the propane flame is about 2200° F.. Certain exposed parts of this machine, when operating, reach 500° F.; the sealant as high as 400° F. and the hydraulic oil may reach 200° F. Always wear protective clothing and eye protection. Be sure that all joints and fittings are tight and leakproof. Immediately replace any hose which shows any signs of wear, fraying or splitting. Tighten all bolts on all flanges after 100 hours. Tighten ALL bolts, nuts and screws every 250 hours.

BURNER CONTROL WIRING DIAGRAM

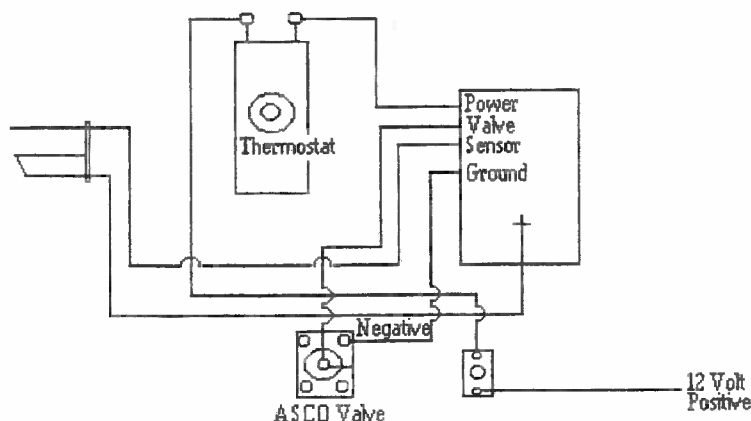

LOADING MACHINE

When loading solid material into the sealant tank, the mixer must be momentarily stopped, the lid lifted, the material placed on the lid and the lid closed again before the mixer is restarted. Following this procedure will prevent the hot material from splashing and causing serious burns to personnel.

The solid materials must be added at intervals which will allow the mixer to rotate without jamming. If blocks of material are fed in too quickly, jamming will result and slow down the melting process.

SHUTDOWN AND CLEAN-OUT PROCEDURE

1. Turn temperature dial to off.
2. Return mixer to off position.
3. Close recirculation valves.
4. Put material pump in suction mode. With hand applicator valve open, disconnect wand and return hose to heat chamber. Leave pump in suction mode for approximately 3 min. Close main tank valve.
5. Return pump to off position.
6. Turn off engine.
7. Return wand to heat chamber.
8. Close applicator valve/open recirculation valve.
9. Close LPG Line Ball Valves. Close LPG Cylinder Valves.

STORING MACHINE

The E-Z Pour 100 should be stored in an area to prevent moisture from entering machine. Extended down time can cause moisture build up in heating oil tank.

Follow procedure below if there is any suspicion that moisture is present: Warm heat transfer oil to 300° F. for 2 to 3 hours to evaporate any moisture.

BURNER TROUBLE SHOOTING GUIDE

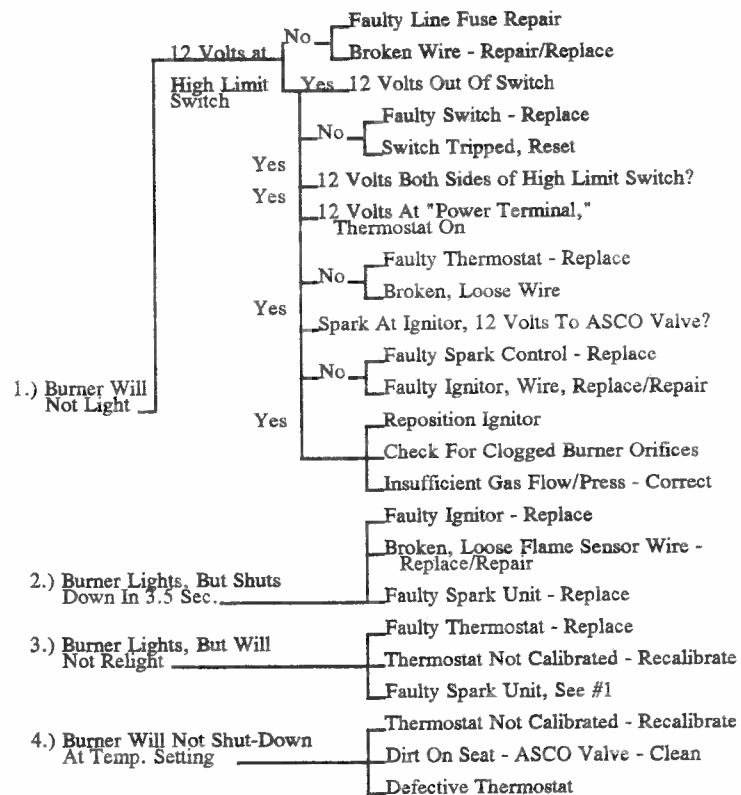

TROUBLE SHOOTING CHART

PROBLEM	CAUSE	REMEDY
Mixer will not rotate.	Sealant temperature too low.	Continue to heat material.
	Too many blocks placed at one time.	Continue to heat material & try reversing mixer.
	Inadequate hydraulic flow/pressure.	Check hydraulic fluid level. Reset pressure/ check flow if necessary.
Material pump will not turn.	Material in tank not to operating temperature.	Continue heating material.
	Hot oil not hot enough to melt material in pump.	Continue heating material.
	Inadequate hydraulic, flow/pressure. pressure.	Check hydraulic fluid level. Reset pressure/ check flow as necessary.
	Material pump damaged or foreign object lodged in pump.	Replace/Remove.
Sealant will not recirculate back into tank through recirculation valve.	Material in tank not to correct temperature.	Continue heating material.
	Drain valve closed.	Open valve.
	Material still cold in suction line. line.	Make sure compartment temperature is adequate to melt material.
	Recirculation valve closed.	Open valve.
Sealant material flows through recirculation valve, but will not flow through application hand wand.	Applicator valve not open.	Open valve.
	Recirculation valve still open or damaged internally.	Close valve or replace.
	Hose/wand still cold.	Leave in chamber until hot.
When applying sealant it stops flowing from applicator wand.	Hand applicator valve was left in off position too long.	Heat hose by placing in heat chamber to liquify sealant.
	Too many blocks of material added to tank. Cold material entered pump & stopped flow.	Heat hose by placing in heating chamber to liquify sealant.
	Tank fluid level too low for material to flow into pump.	Continue heating material until more liquid material is available.
Pump rotates, but will not pump material.	Material pump worn or damaged.	Replace/Repair
	Pump rotating in wrong direction.	Reverse control lever.
	Foreign object lodged in inlet line to pump.	Dislodge by reversing pump or disassemble inlet line.
	Material cold, inlet still solid.	Continue to heat material.
Slow heat up of sealant.	Build up of coked or crystallized material on inside of material tank.	Allow machine to cool. Remove deposits and flush with solvent.
	Burner not operating/low LPG pressure.	Repair/Adjust.
	Low heating oil level.	Check level of Heat Transfer oil.
	Low heating oil temperature	Set at recommended temperature

SERVICE INSTRUCTIONS

1. Conduct a general inspection of your machine at least once a week. Replace all worn or damaged parts, make any necessary adjustments and tighten all loose nuts or screws.
2. Keep regular replacement items in stock for emergency repairs, to avoid costly "down" time. Refer to general maintenance items, page 20.
3. Clean machine externally periodically. Check with sealant manufacturer for recommendation.
4. Follow recommended maintenance procedures on maintenance chart.

MAINTENANCE INSTRUCTIONS

ENGINE:

Check oil every 8 hours of operation. Change after the first 5 hours of operation and change every 25 hours thereafter.

See engine owners manual for additional operating and maintenance instructions.

HYDRAULIC SYSTEM:

Check hydraulic fluid every 8 hours. Change hydraulic filter after first 10 hours of operating and every 250 hours thereafter. Change hydraulic fluid every 500 hours of operation.

WHEEL BEARINGS:

Repack wheel bearings every 24,000 miles or every two years, using a good grade of bearing grease.

TONGUE JACK:

Lubricate tongue jack, using a good grade of bearing grease.

SEALANT PUMP:

Lubricate outboard bearings using a good grade of bearing grease. Adjust pump packing periodically. A slight drippage (several drops per minute) should be allowed. Refer to Pump Section for details. See page 18.

MAINTENANCE CHART

LOCATION	PROCEDURE	HOURS			
		8	50	100	500
Engine Check Oil Level	See Engine Instruction Manual.	*			
Other Engine Maintenance	See Engine Operating and Maintenance Instructions.				
Battery	Maintenance Free.				
Pump Packing	Tighten as required. Drip should be several drops/per minute.		*		
Pump Outboard Bearing	Lubricate using a good grade of bearing grease.		*		
Heat Transfer Oil	Check (every 8 hours).		*		
	Change	after 500 hours or 1 year.			
Hydraulic Oil Return line filter	First change. (10 hours)	*			
	Subsequent changes. 250 (hours)			*	
Hydraulic Oil	Check Oil (every 8 hours)	*			
	Change Oil (every 500 hours)				*
	For proper oil, see recommended fluids & lubricants, page 19.				
Wheel Bearings	Clean & repack - using good grade of bearing grease.	Every 24,000 miles or every two Years.			
Tongue Jack	Grease, using good grade of bearing grease.	Once a Year.			
Applicator Hose	Replace	After 100 hours or as needed.			

PUMP SECTION PACKING INSTRUCTIONS

Operate the pump under normal conditions and, after a short run-in period, examine packing for leakage. If leakage is excessive tighten locknuts evenly until there is only slight leakage from the packing rings. This slight leakage is a necessary and normal condition for packing and allows for expansion and proper seating.

NOTE: WHERE LIQUID IS BEING HANDLED THAT IS HAZARDOUS OR VOLATILE, FULL PRECAUTIONS SHOULD BE TAKEN DURING THE RUN-UP PERIOD.

To replace packing remove key, two nuts and clips, packing gland and packing rings. (Packing hooks are commercially available to assist in removing the packing rings). Clean the shaft and adjacent parts. Examine the shaft, if it is excessively worn or scored, replacement of pump may be necessary.

Insert packing rings, making sure the joints are staggered 180 degrees. Use split ring bushings to seat each ring before adding the next ring. The rings must not be tamped or seated in place too tightly. When the packing box is sufficiently full to allow entry of the packing gland (about 1/4") reassemble the packing gland, clips and nuts. Draw up evenly on the packing gland to assure proper seating of the packing, and then loosen nuts about 1/2 turn. Do not cock the packing gland. (This could cause binding or heating of the shaft).

Operate the pump under normal conditions & after a short run-in period, examine packing for leakage. If leakage is excessive, tighten locknuts evenly at 1/2 turn intervals until there is only slight leakage from packing rings.

RECOMMENDED FLUIDS & LUBRICANTS

APPLICATION	RECOMMENDED	FULL POINT
Engine Oil	Refer to Onan Owners Manual.	2 Qts.
LPG	Propane	200 Lbs.
Hydraulic Oil	RONDO OIL-HD-68 Texaco	10 Gal.
Heat Transfer Oil		27 Gal.

The following is a list of suitable Heat Transfer Oils to be used in CrafcO equipment.

<u>Producer</u>	<u>Product Name</u>	<u>Product No.</u>
Texaco	Regal	R & O 68
Gulf	Harmony	68
Shell	Thermia	"C"
Exxon	Teresstic	68
Phillips	Magnus	68
Chevron USA	Heat Transfer Oil #1	
Conoco	Dectol R & O	68
Union Oil	Turbine Oil	68

WARNING

The Heat Transfer Oil in this machine is a grade that has been tested and recommended by CRAFCO, Inc. The addition of any grade of oil not specifically recommended by CRAFCO, Inc. shall be cause for the voidance of all warranties.

All oils subjected to high temperatures deteriorate with time and lose many of their characteristics. Tests conducted by CRAFCO, Inc. have determined that for best results and safety, the Heat Transfer Oil in this machine must be drained and replaced with CrafcO, Inc. recommended oil after five hundred (500) hours of operation or one (1) year, whichever occurs first.

GENERAL MAINTENANCE ITEMS

RECOMMENDED QUANTITY	DESCRIPTION	PART NO.
1 Set	Packing, Sealant Pump	29990
1	Sealant Hose 15'	27084
1	Ignitor	25277
1	Hydraulic Filter	22071
1	Air Cleaner	32139
1	Air Cleaner Wrapper	32140

INSTRUCTION FOR ORDERING PARTS

Parts may be ordered from your local CRAFCO distributor or directly from CRAFCO, Inc. if a distributor is not available in your area. When ordering parts, give the following information:

1. Part Number
2. Machine Model
3. Serial Number from Name Plate

Write or telephone:

CRAFCO, INC.
6975 WEST CRAFCO WAY
CHANDLER, AZ 85226
(602) 276-0406
Toll Free: 1-800-528-8242

PARTS LIST

ITEM NO.	DESCRIPTION	QTY.	PART NO.
1.	Tire & Wheel Assembly	2	41743
2.	Axle Assembly with Springs	1	41560
3.	Shackle Tie Plate	4	23075
4.	Shackle Bolt	6	23100
5.	Shackle Nut	6	23105
6.	Fender, L.H. Assembly	1	41575
7.	Fender, R.H. Assembly	1	41576
8.	5/16 - 18 x 1 Bolt	8	28716
9.	5/16 Fender Washer	8	28681
10.	5/16 - 18 Lock Nut	8	28525
11.	Tail Light - L.H.	1	24023
12.	Tail Light - R.H.	1	24022
13.	1/4 Flat Washer	4	28670
14.	1/4 Lock Washer	4	28645
15.	1/4 - 20 Hex Nut	10	28500
16.	Tongue Jack - Side Mount	1	23097
17.	Jack Swivel Bushing	1	23096
18.	Breakaway Switch Unit	1	23117
19.	12.5 HP Onan Engine	1	41691
20.	Hydraulic Pump	1	41582
21.	3/8 - 16 x 1 Bolt	10	28731
22.	3/8 - 16 Lock Nut	14	28538
23.	5/8 Jaw Coupling	1	41167
24.	1" Jaw Coupling	1	41168
25.	Coupling Spider	1	41169
26.	Hydraulic Reservoir	1	41520
27.	3/8 - 16 x 3/4 Bolt	4	28730
28.	Air Breather & Element	2	26025
29.	Dipstick Assembly	1	41162
30.	Hydraulic Filter & Element	1	22070
31.	1" Close Nipple	1	28005
32.	LPG Storage Tank	2	25118
33.	Knob	2	26032
34.	Overflow Tank	1	41553
35.	4 Hole Flange Gasket	2	29051
36.	3/8 - 16 Esna Lock Nut	8	28526
37.	Dip Stick Assembly	1	41199
38.	3/8 Pipe Coupling	2	28177
39.	Stuffing Box	2	25203
40.	1/2 Pipe Coupling	2	28178
41.	1/2 x 1/4 Bushing	1	28344
42.	Temperature Gage - 24"	1	41243
43.	Temperature Gage - 12"	1	40078
44.	Mounting Plate	1	40029
45.	Pipe Spacer	4	40030
46.	3/8 - 16 x 2 Bolt	4	28736
47.	3/8 Lockwasher	16	28647
48.	Agitator Motor	1	22310
49.	3/8 - 16 x 1 1/4 Bolt	12	28732

ITEM NO.	DESCRIPTION	QTY.	PART NO.
50.	Agitator Shaft Assembly	1	41690
51.	Paddle Assembly	2	41587
52.	Flange Assembly	2	41153
53.	Burner Assembly	1	41210
54.	Ignitor Assembly	1	41686
55.	Flow Divider	1	41573
56.	Material Pump Control Valve	1	41092
57.	¼ - 20 x 1½	6	28704
58.	2" Sealant Pump	1	27029
59.	½ - 13 x 1¾ Bolt	4	28763
60.	1/2" Lockwasher	4	28649
61.	1/2" Flat Washer	4	28674
62.	1/2 - 13 Hex Nut	4	28504
63.	Hydraulic Motor	1	22027
64.	3/8 - 16 x 3/4 Bolt	4	28730
65.	3/8 Lockwasher	4	28647
66.	Chain Sprocket	2	26002
67.	Dual Sprocket Chain	1	26016
68.	Connecting Link	1	26030
69.	Chain Guard	1	41140
70.	5/16 Lockwasher	1	28646
71.	5/16 - 18 Hex Nut	1	28501
72.	Key - Sealant Pump	1	27017
73.	Agitator Control Valve	1	41093
74.	9" Temperature Gage	1	25057
75.	Flanged Nipple Assembly	2	22030
76.	Flanged Nipple Assembly	2	22030
77.	3/8 - 16 x 1 Bolt	40	28731
78.	3/8 - 16 Stover Nut	40	28538
79.	Pipe Assembly - Upper	1	41680
80.	Recirculation Valve	1	41246
81.	Elbow - Recirculation Line	1	41679
82.	Flange Tee	1	41597
83.	Double Elbow Assembly	1	41596
84.	Lower Suction Tee	1	41657
85.	2" Pipe Cap	1	28273
86.	Flanged Gate Valve	1	29292
87.	Valve Handle Extension	1	41268
88.	Gasket - 8 Hole	2	29060
89.	Flange Assembly - Suction	1	41660
90.	3/8 Close Nipple	1	28002
91.	3/8 Ball Valve	1	29202
92.	3/8 x 90 Street Elbow	1	28237
93.	3/8 Pipe Plug	1	28282
94.	2" Gate Valve	1	29270
95.	2" x 8" Pipe Nipple	1	28110
96.	2" x 90° Elbow	2	28213
97.	Cross Feed Pipe	1	41291
98.	U Bolt Pipe Hanger	1	41623
99.	2½" Temperature Gauge	1	25050

ITEM NO.	DESCRIPTION	QTY.	PART NO.
100.	2 x 1 Reducing Bushing	1	28358
101.	Male - Female Swivel	2	27048
102.	Sealant Hose Assembly	1	27084
103.	Handle Assembly with Valve	1	41208
104.	1" Ball valve	1	29240
105.	Handle Assembly	1	27080
106.	1 x 3/4 Reducing Bushing	1	28351
107.	3/4 x 8" Pipe Nipple	1	28100
108.	Hand Wand Assembly	1	41629
109.	Sealing Tip Assembly	1	27171
110.	Control Box Assembly	1	41698
111.	Clamp - Control Box	2	25268
112.	Thermostat - 550°	1	25276
113.	#6 x 3/8 Long: Stl. Thread Forming Screw	2	28832
114.	Temperature Dial	1	25220
115.	Spark Control Module	1	25278
116.	#8 - 32 x 1" Long Bolt	4	28833
117.	#8 - 32 Hex Nut	4	28835
118.	Manual Reset	1	25240
119.	#6 - 32 x 1/2 Screw	2	28838
120.	#6 - 32 Hex Nut	2	28839
121.	90° Elbow Adaptor	3	29871
122.	1/4 Pipe Coupling	1	28176
123.	1/4 x 4" Long Pipe Nipple	2	28035
124.	Burner Servo Cont. Valve	1	25236
125.	1/4 x 2" Long Pipe Nipple	1	28043
126.	Bulkhead Coupling	1	29830
127.	Straight Adaptor	3	29839
128.	LPG Hose 12" Long	1	25137
129.	Strainer	1	25208
130.	1/4 Ball Valve	1	29195
131.	¼ x 1½ Pipe Nipple	2	28012
132.	1/4" Pipe Tee	2	28251
133.	Indicator Light	1	24140
134.	Gravity Feed Option	1	41661
135.	2 x 90° Street Elbow	1	28243
136.	2" Gate Valve	1	29270
137.	2 x 11 Pipe Nipple	1	28150
138.	2" Coupling	1	28183
139.	2" Oil Gate Valve	1	29280
PARTS NOT ILLUSTRATED			
	Hour Meter	1	24076
	Battery Cable	1	37038
	Battery Cable	1	41624
	Wiring Harness (Control Box)	1	25272
	Wiring Harness (Ignitor)	1	41641

HYDRAULIC PIPING - E-Z POUR 100 MELTER

1. HYDRAULIC RESERVOIR TO HYDRAULIC PUMP (SUCTION)		
1	29878	Elbow Adaptor
1	29573	Hydraulic Hose Assembly 3/4 x 33" Long
1	29916	Elbow Adaptor "O" Ring

2. HYDRAULIC PUMP (PRESS.) TO FLOW DIVIDER VALVE ("IN" PORT)		
1	29812	Straight Adaptor
1	29579	Hydraulic Hose Assembly 1/2 x 36" Long
1	29805	Bulkhead Connector
1	29807	Bulkhead Locknut
1	41552	Tube Assembly
1	29805	Bulkhead Connector
1	29807	Bulkhead Locknut
1	29815	Pipe Swivel Connector
1	28348	Reducing Bushing 3/4 x 1/2

3. FLOW DIVIDER VALVE ("PB" PORT) TO MATERIAL VALVE ("IN" PORT)		
1	28348	Reducing Bushing 3/4 x 1/2
1	29841	Straight Adaptor
1	40012	Hydraulic Hose Assembly 3/8 x 24" Long
1	29872	Elbow Adaptor
1	28347	Reducing Bushing 3/4 x 3/8

4. MATERIAL VALVE ("OUT" PORT) TO HYDRAULIC FILTER ("IN" PORT) RETURN		
1	29813	Elbow Adaptor
1	29566	Hydraulic Hose Assembly 1/2 x 19" Long
1	29811	Swivel Nut Run Tee
1	29805	Bulkhead Connector
1	29807	Bulkhead Locknut
1	41552	Tube Assembly
1	29805	Bulkhead Connector
1	29807	Bulkhead Locknut
1	29567	Hydraulic Hose Assembly 1/2 x 41" Long
1	29813	Elbow Adaptor
1	28351	Reducing Bushing 1 x 3/4

5. HYDRAULIC FILTER ("OUT" PORT) TO HYDRAULIC RESERVOIR		
1	28005	1" Close Nipple

6. FLOW DIVIDER VALVE ("REG" PORT) TO MIXER VALVE ("IN" PORT)		
1	28347	Reducing Bushing 3/4 x 3/8
1	29872	Elbow Adaptor
1	40012	Hydraulic Hose Assembly 3/8 x 24" Long
1	29876	Elbow Adaptor
1	28348	Reducing Bushing 3/4 x 1/2

7. MIXER VALVE ("OUT" PORT) TO TEE IN LINE 4.		
1	29813	Elbow Adaptor
1	29566	Hydraulic Hose Assembly 1/2 x 19" Long

8. MIXER VALVE ("INBOARD" PORT) TO HYDRAULIC MOTOR FOR MIXER (L.H. PORT)		
1	29841	Straight Adaptor
1	40187	Hydraulic Hose Assembly 3/8 x 18" Long
1	29808	Tube Connector
1	41550	Tube Assembly
1	22029	Straight Adaptor "O" Ring

9. MIXER VALVE ("OUTBOARD" PORT) TO HYDRAULIC MOTOR FOR MIXER (R.H. PORT)		
1	29841	Straight Adaptor
1	40187	Hydraulic Hose Assembly 3/8 x 18" Long
1	29808	Tube Connector
1	41551	Tube Assembly
1	22029	Straight Adaptor "O" Ring

10. MATERIAL VALVE ("INBOARD" PORT) TO HYDRAULIC MOTOR FOR MATERIAL PUMP (BOTTOM PORT)		
1	29876	Elbow Adaptor
1	29570	Hydraulic Hose Assembly 3/8 x 34" Long
1	22029	Straight Adaptor "O" Ring

11. MATERIAL VALVE ("OUTBOARD" PORT) TO HYDRAULIC MOTOR FOR MATERIAL PUMP (TOP PORT)		
1	29876	Elbow Adaptor
1	29570	Hydraulic Hose Assembly 3/8 x 34" Long
1	22029	Straight Adaptor "O" Ring

LPG PIPING SEQUENCE E-Z POUR 100 MELTER

1. L.H. L.P.G. TANK TO STRAINER ON CONTROL BOX		
1	25073	L.P.G. Regulator Assembly - consists of: 25123 Tank Spud 25066 Pressure Regulator 28001 1/4 Close Nipple 29195 1/4 Ball Valve 29857 45° Elbow Adaptor
1	25141	L.P.G. Hose 3/8 x 44" Long
1	29839	Straight Adaptor (On Control Box)
1	28251	1/4 Pipe Tee (#1) (On Control Box)
1	28012	1/4 x 1 1/2 Pipe Nipple (On Control Box)
1	28251	1/4 Pipe Tee (#2) (On Control Box)
1	28012	1/4 x 1 1/2 Pipe Nipple (On Control Box)
1	29195	1/4 Ball Valve (On Control Box)
1	28035	1/4 x 4 Pipe Nipple (On Control Box)
1	25208	Strainer (On Control Box)

2. R.H. L.P.G. TANK TO TEE #2 IN LINE 1.		
1	25073	L.P.G. Regulator Assembly - Consists of: 25123 Tank Spud 25066 Pressure Regulator 28001 1/4 Close Nipple 29195 1/4 Ball Valve 29857 45° Elbow Adaptor
1	25142	L.P.G. Hose 3/8 x 31" Long
1	29839	Straight Adaptor (On Control Box)

3. STRAINER ON CONTROL BOX TO CONTROL BOX (IN)		
1	29871	Elbow Adaptor (On Control Box)
1	25137	L.P.G. Hose 3/8 x 12" Long
1	29839	Straight Adaptor (On Control Box)

4. L.P.G. REGULATOR TO BURNER		
1	29871	Elbow Adaptor (On Control Box)
1	25138	L.P.G. Hose 3/8 x 37" Long
1	29871	Elbow Adaptor
1	28344	Reducing Bushing 1/2 x 1/4
1	41082	L.P.G. Regulator

5. L.P.G. REGULATOR TO BURNER		
1	28026	1/2 x 3" Long Pipe Nipple
1	28253	1/2 Pipe Tee
1	29832	Straight Adaptor
1	25132	L.P.G. Hose 3/8 x 34" Long
1	29832	Straight Adaptor

6. TEE #1 IN LINE 1. TO GOVERNOR		
1	29871	Elbow Adaptor (On Control Box)
1	25146	L.P.G. Hose 3/8 x 23" Long
1	29839	Straight Adaptor
1	25087	Fisher Regulator
1	28012	1/4 x 1 1/2 Pipe Nipple
1	25086	Governor

7. GOVERNOR TO ENGINE		
1	20985	Elbow Adaptor
1	26079	Gear Clamp
1	29585	L.P.G. Fuel Line 3/8 x 50" Long
1	26079	Gear Clamp

8. TEE IN LINE 5.		
1	28283	1/2" Pipe Plug

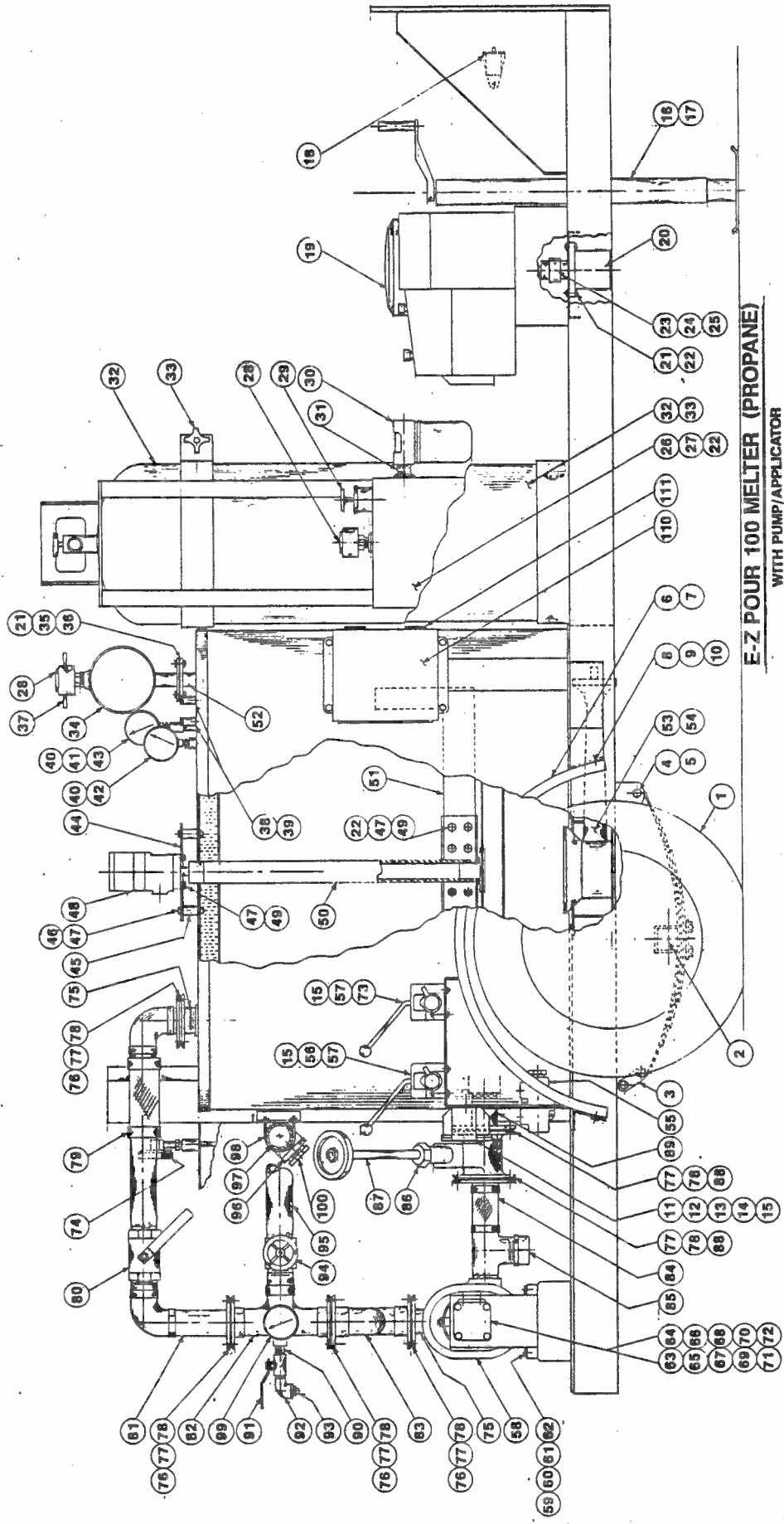

E-Z POUR 100 MELTER (PROPANE)
 WITH PUMP/APPLICATOR

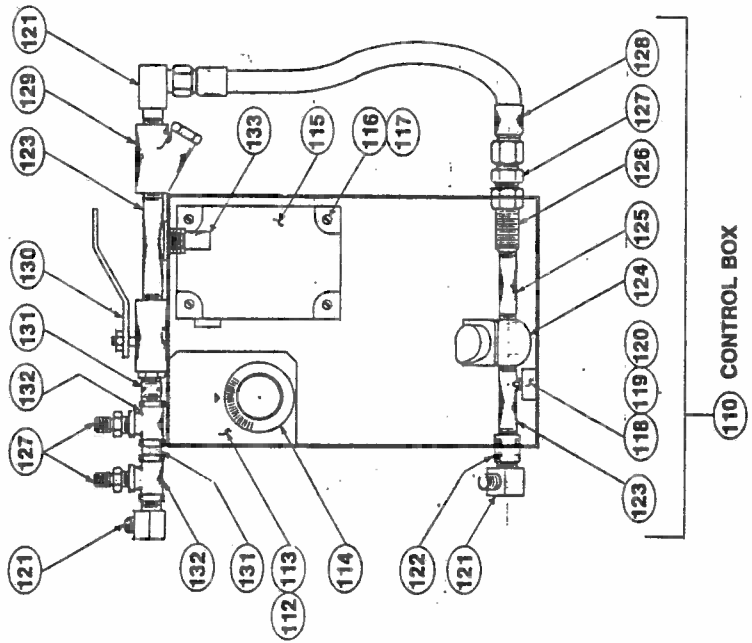
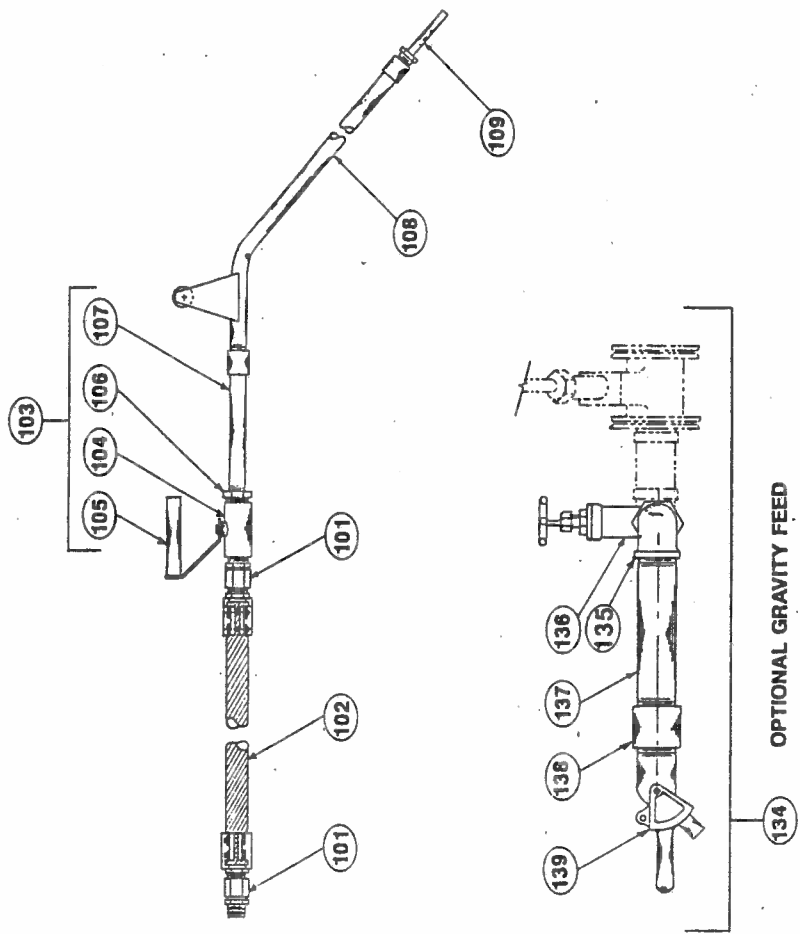

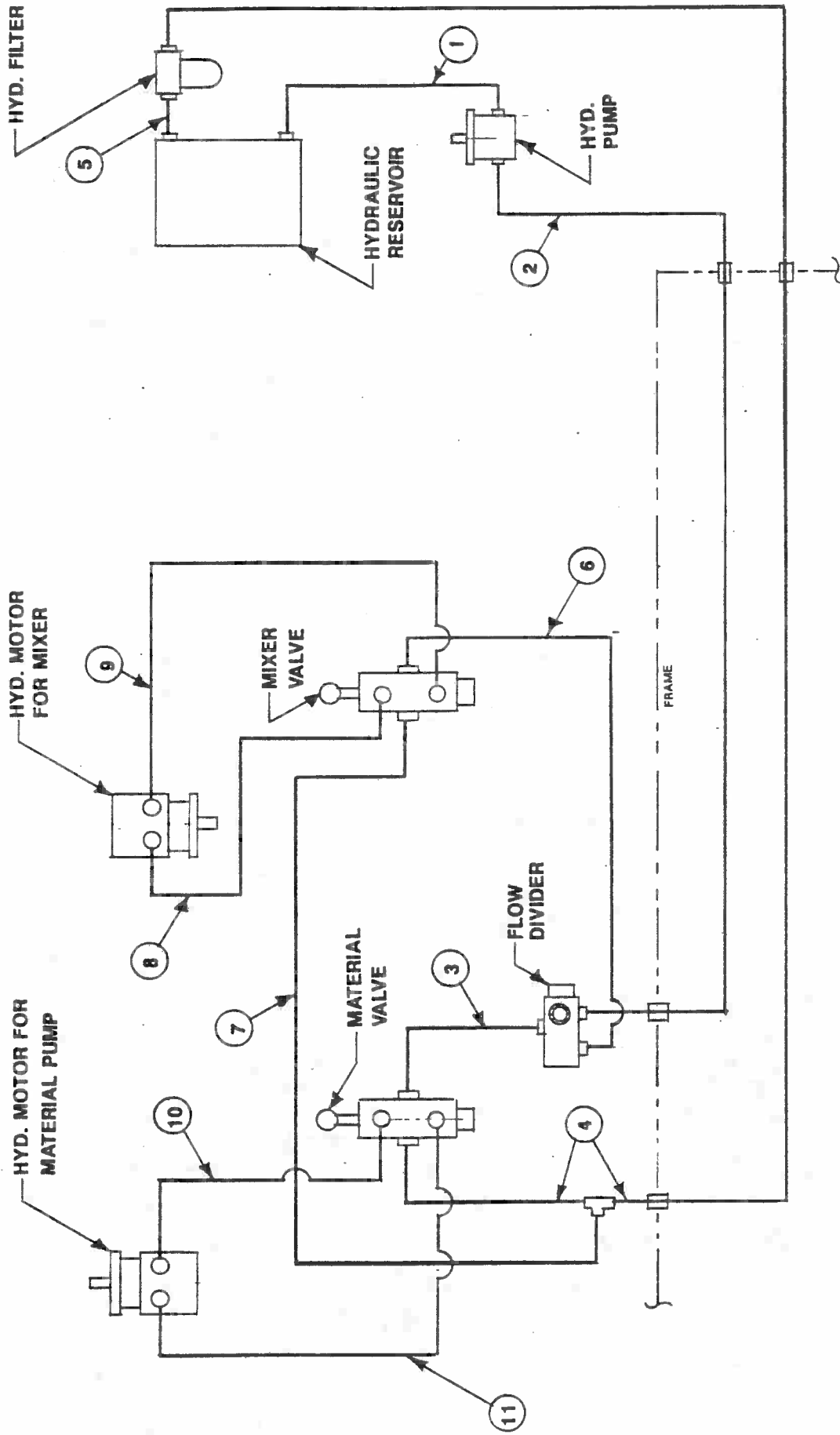

HYDRAULIC PIPING DIAGRAM

E-Z Pour 100 Melter (Propane)

WITH PUMP/APPLICATOR

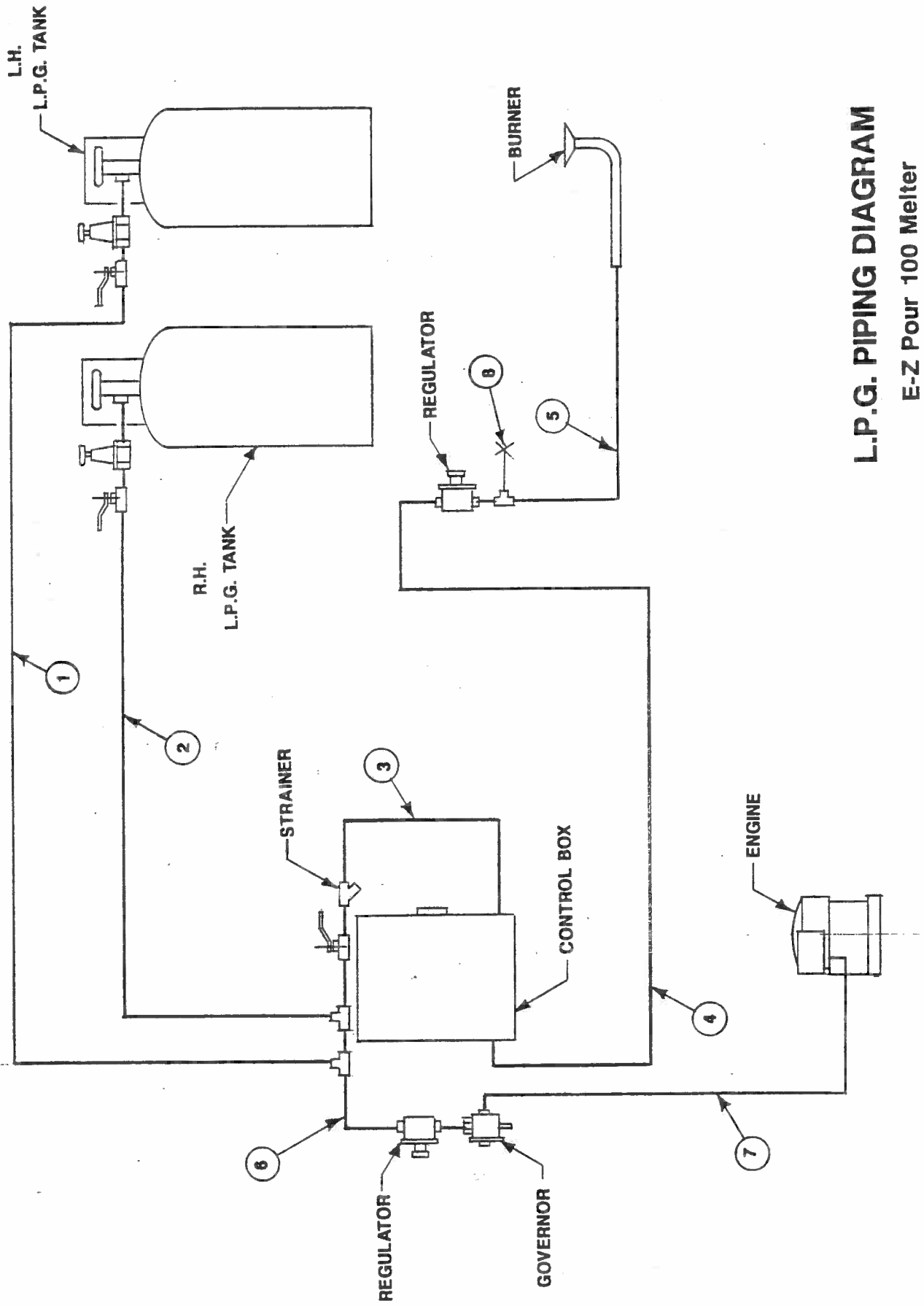

L.P.G. PIPING DIAGRAM
E-Z Pour 100 Melter
WITH PUMP/APPLICATOR